

Tidal Energy Resources, Technology, and Research

Brian Polagye

Northwest National Marine Renewable Energy Center
University of Washington

UW Water Symposium

April 30, 2013

Harnessing Tidal Energy

Potential Energy - Barrage



Height
Difference

$$P = \rho Qgh$$

Flow Rate

Kinetic Energy - Turbine

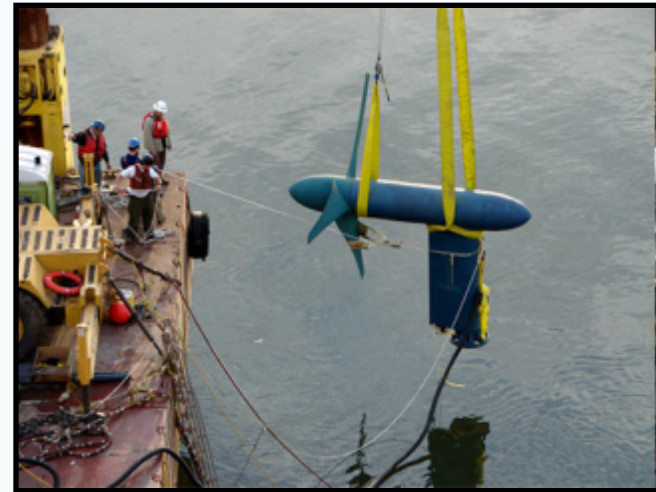

Swept Area

$$P = \frac{1}{2} \rho u^3 A$$

Velocity

Potential Locations in Washington

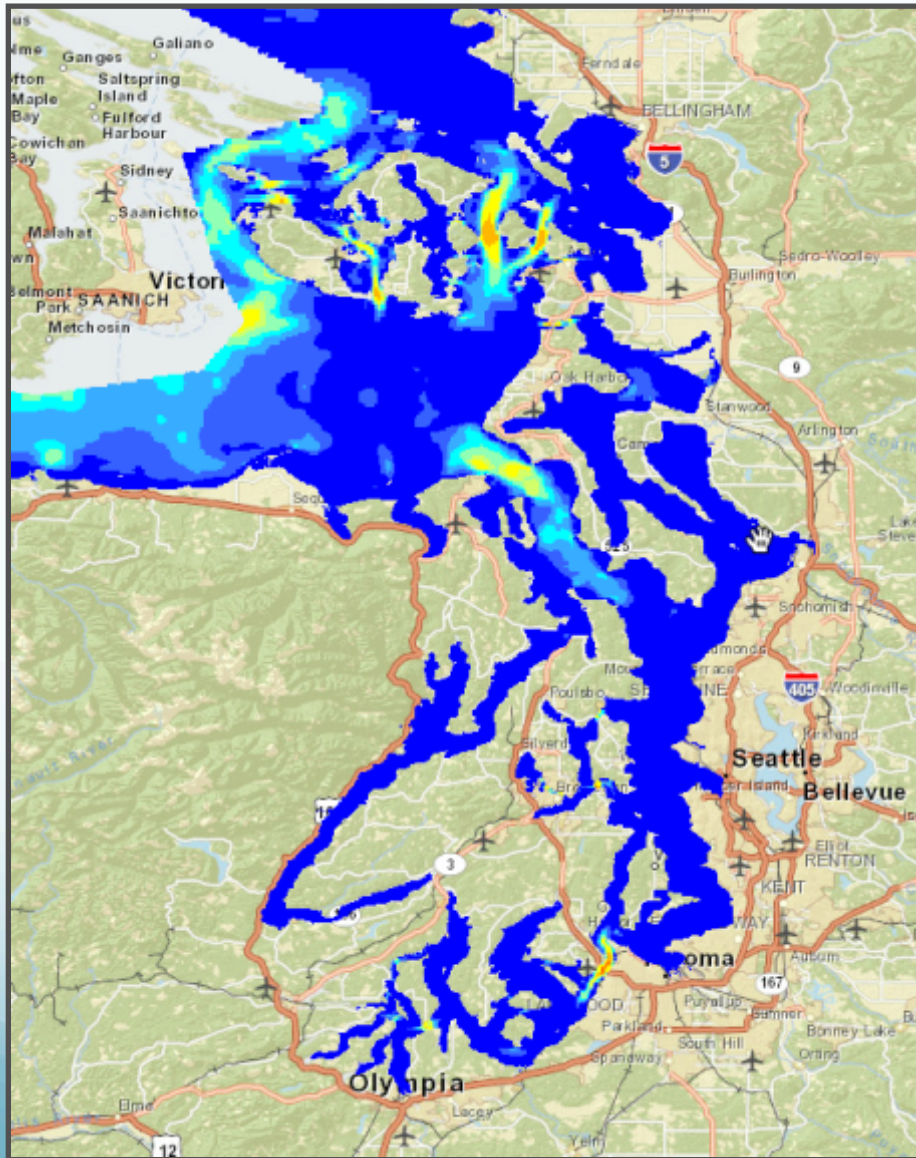

- Highest resource intensity in narrow channels
- Theoretical resource on the order of 1 GW
- Demonstration project proposed for Admiralty Inlet

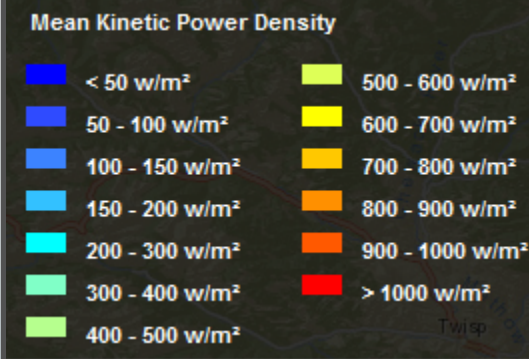

$$P = \frac{1}{2} \rho U^3 A$$



Why the Interest?

Challenges

- Limited locations and available resource
- Intermittent resource
- Evolving technology
- Poorly understood environmental and social impacts
- Higher cost of energy than conventional power sources (particularly shale gas)

Opportunities

- Renewable, zero-emission power generation
- High resource intensity compared to other renewables
- Predictable resource
- Low/no viewshed impacts
- Resource close to population centers
- Modular, flexible technology



Components of a Current Turbine

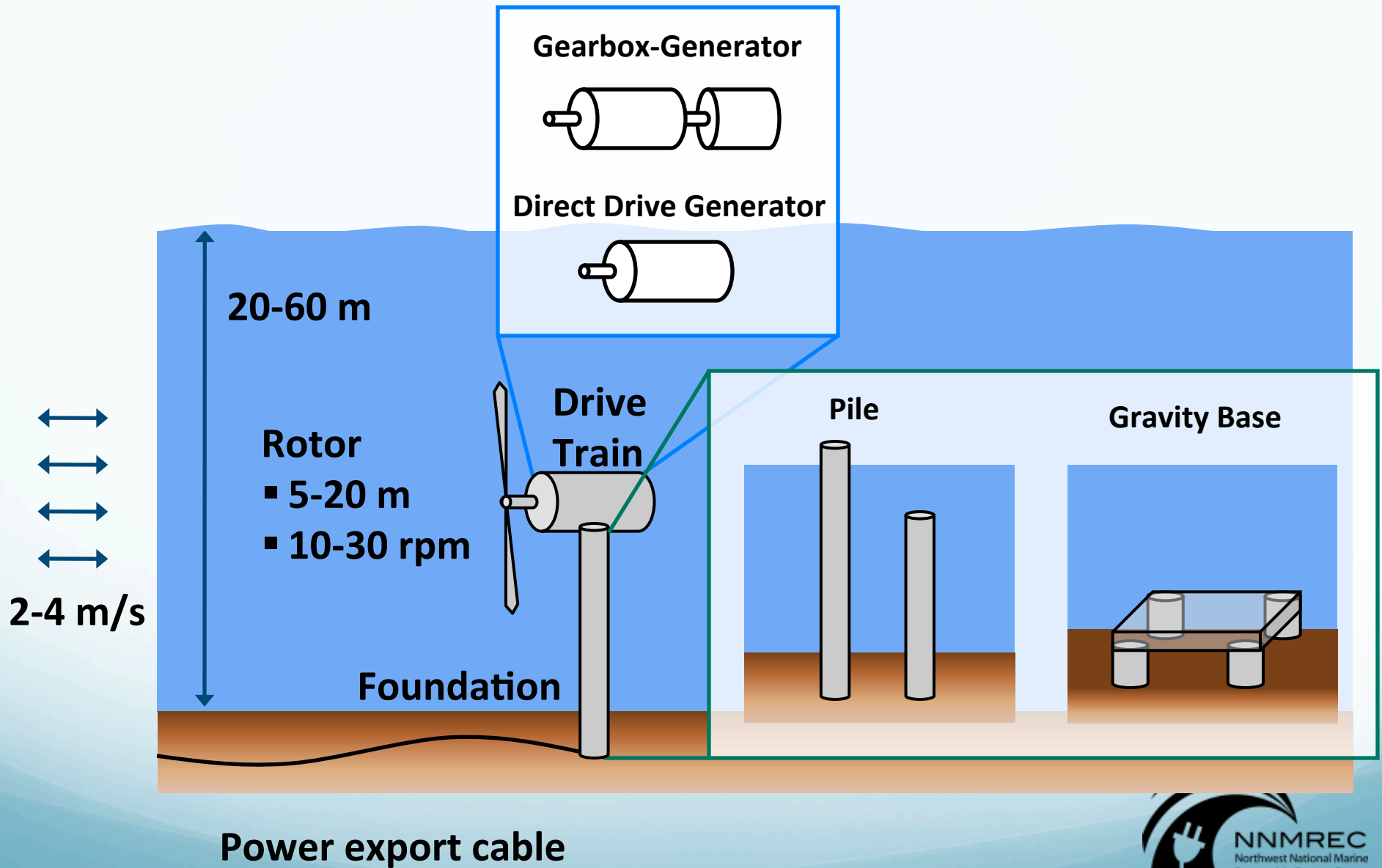

Worldwide Technology Demonstrations

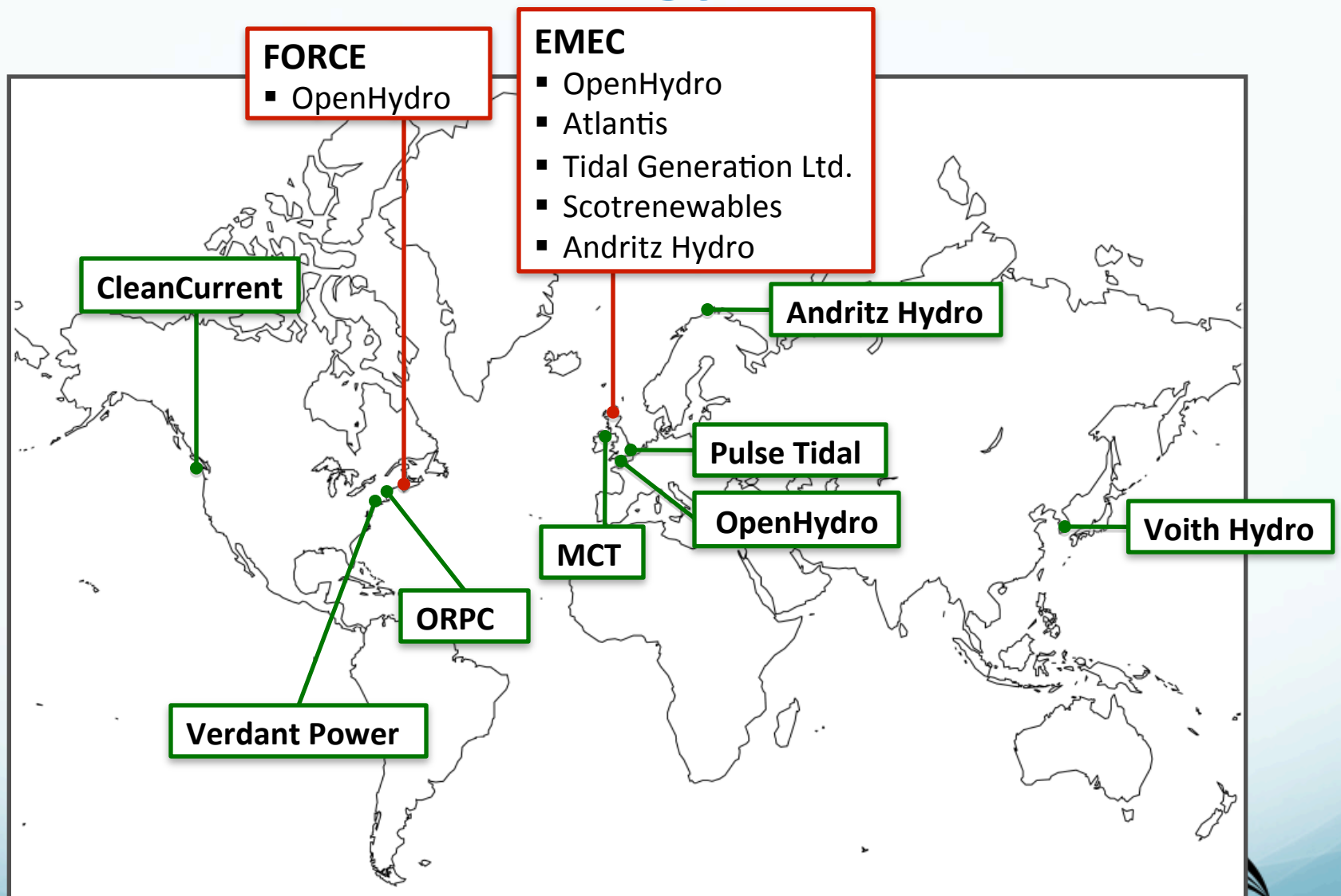

Worldwide Technology Demonstrations

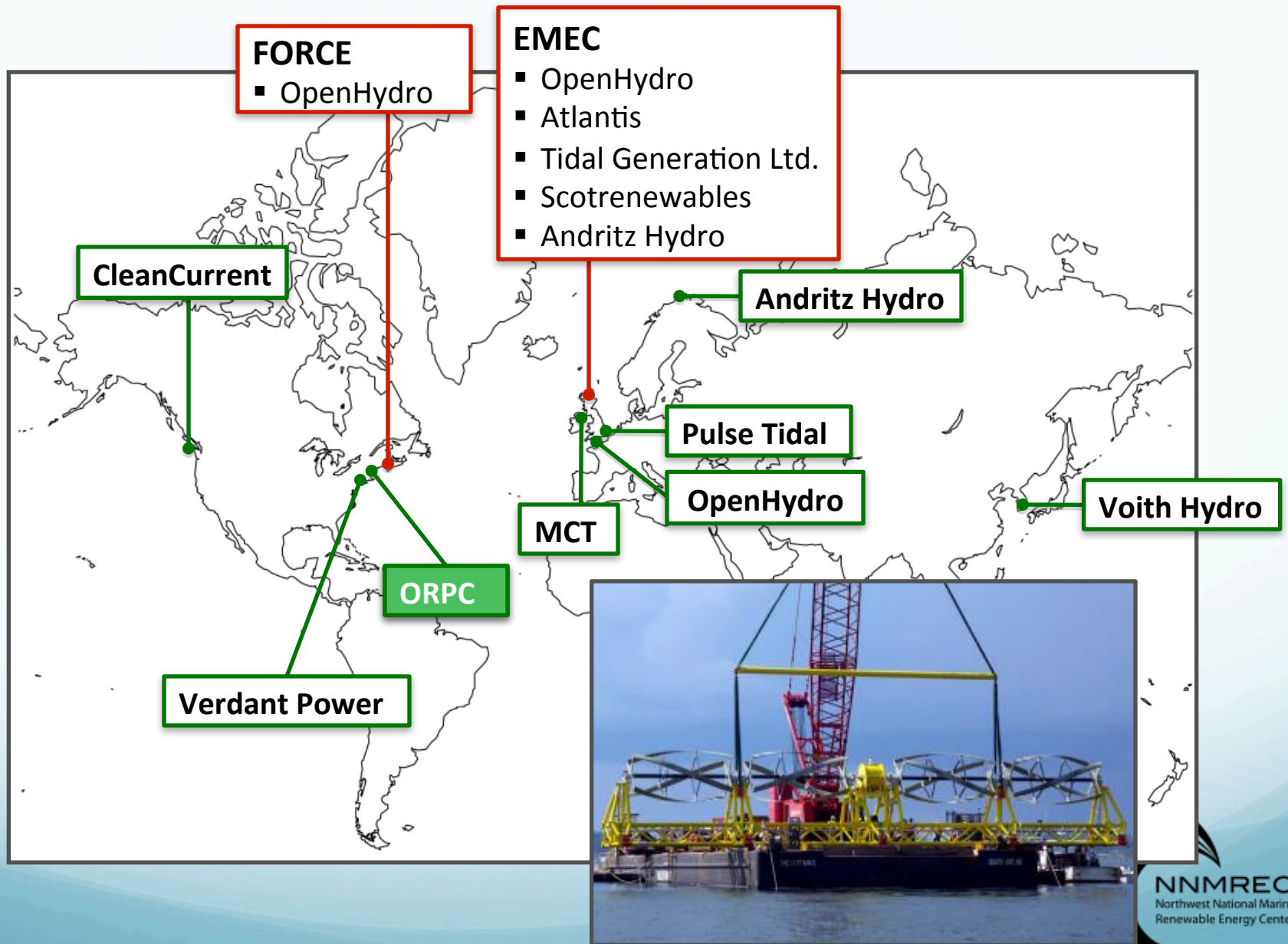

Worldwide Technology Demonstrations

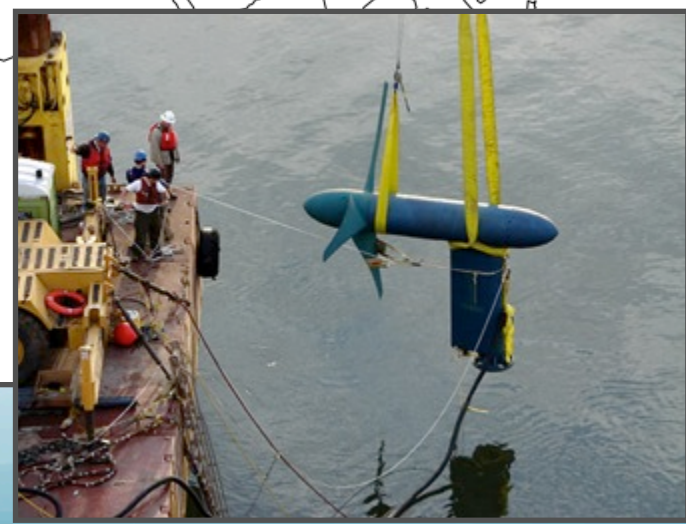
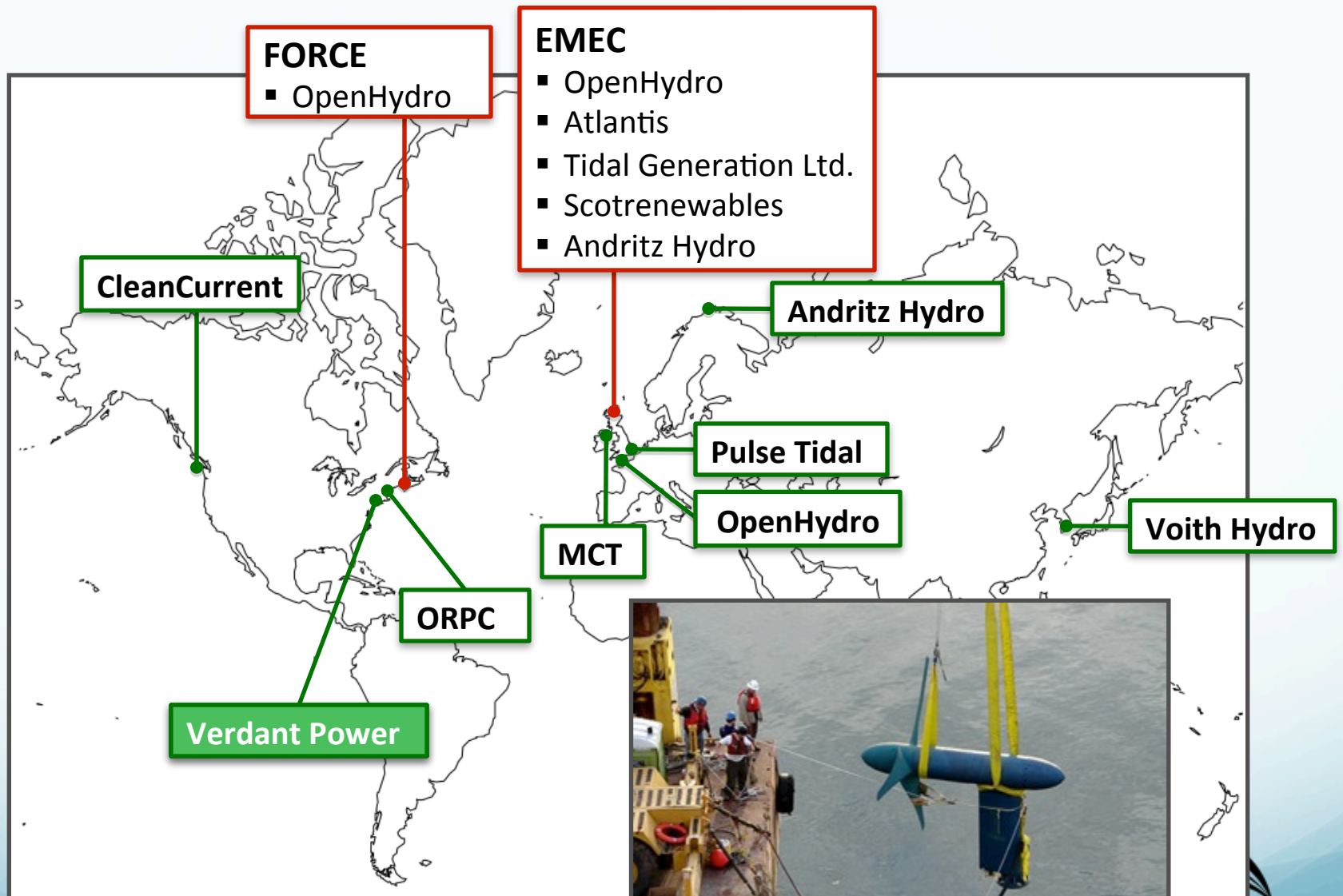

Worldwide Technology Demonstrations

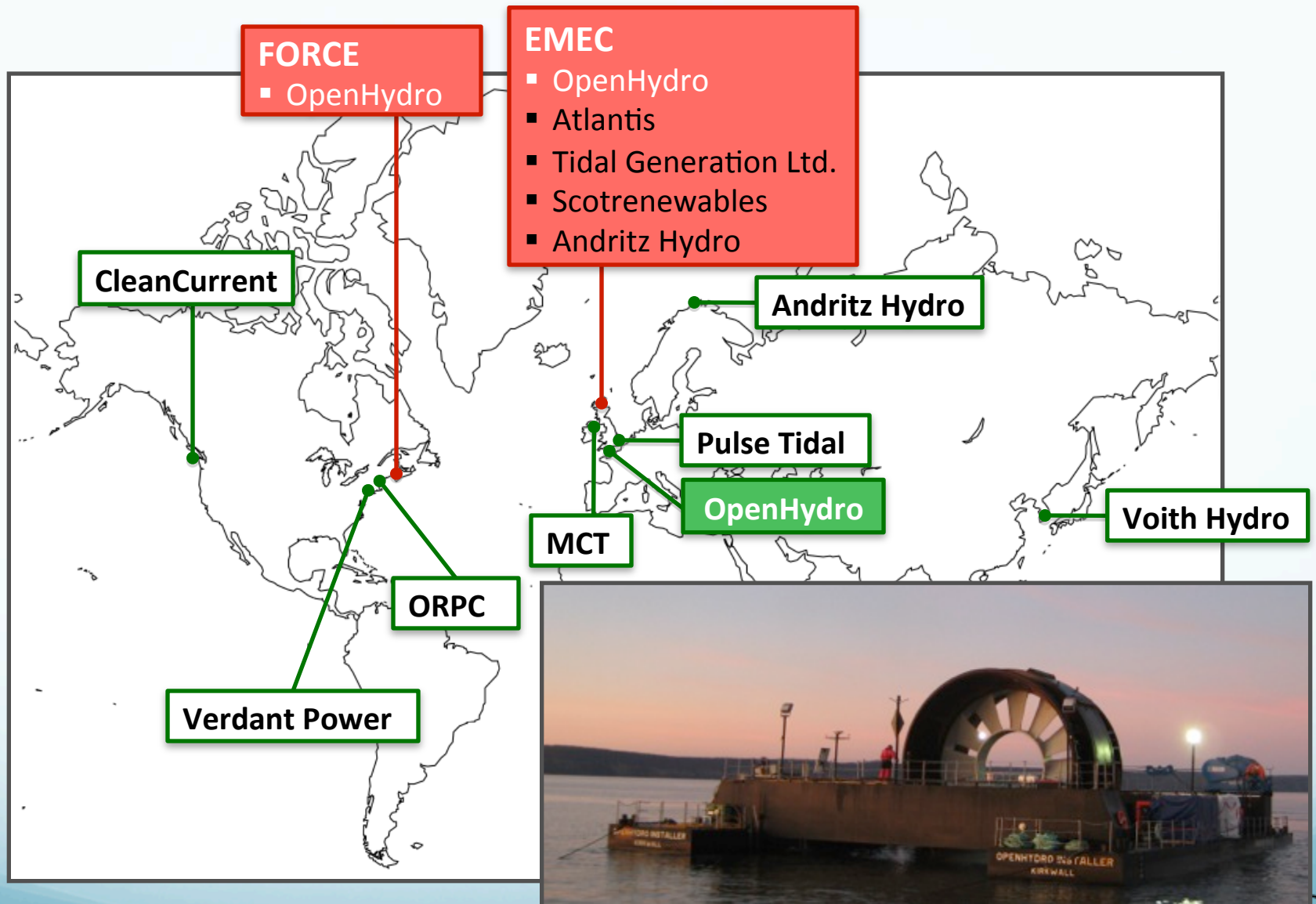

Worldwide Technology Demonstrations

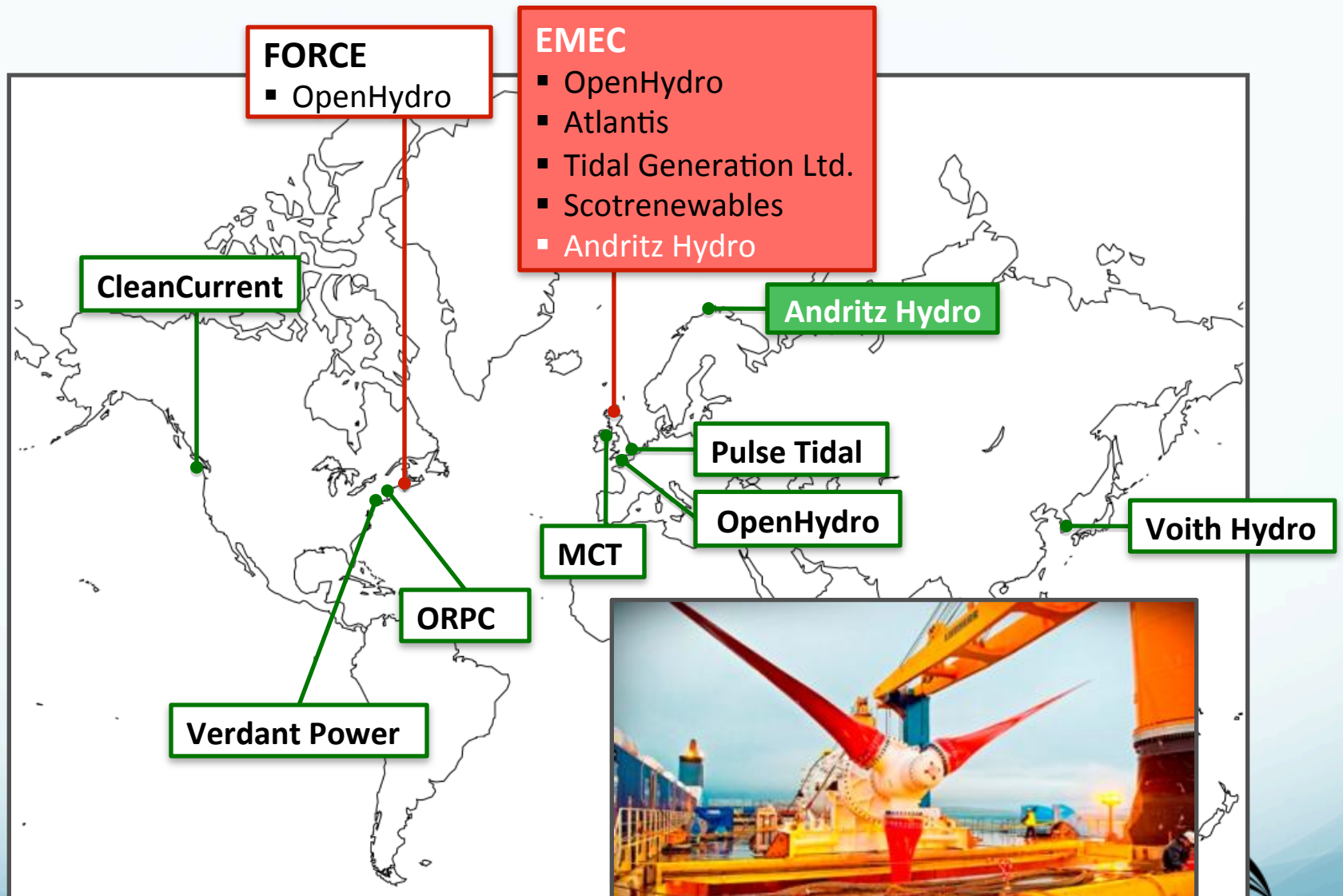

Worldwide Technology Demonstrations

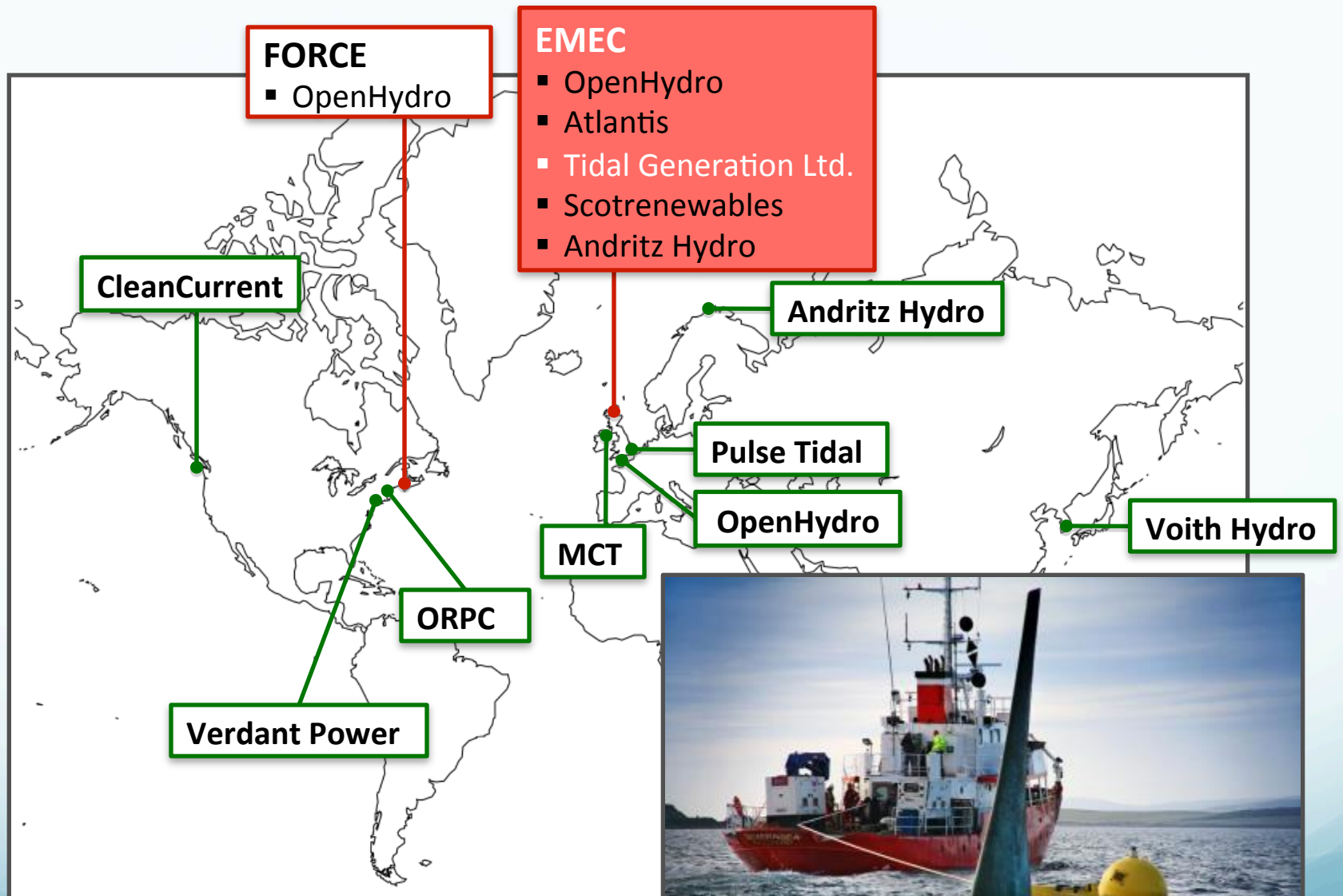

Worldwide Technology Demonstrations

